

Technical Manual

Beta 20



ACOUSTIC & ELECTRICAL SPECIFICATIONS:

- Nominal Impedance 8Ω
- Max Amp Power 150 watts*
- Frequency Response 58Hz – 20kHz (±3dB)
52Hz – 40kHz (-6dB)
- Sensitivity 90dB (2.83V @ 1 meter)
- Crossover Frequency 2.4kHz; 12dB/Octave

SYSTEM COMPONENTS:

- Cabinet Beta 20 (Not for Sale)
352006-003
- Grille Black (for BLK) 352006-004
Gray (for BE & CH)
- Low-Frequency Transducer 6-1/2" (165mm) CMMD™, magnetically shielded 351505-001
- DC Resistance 4.6 ohms ±10%
- High-Frequency Transducer 1" (25mm) CMMD™, magnetically shielded 351572-001
- DC Resistance 3.5 ohms ±10%
- Crossover Network 351570-001

AURAL SWEEP TEST SPECIFICATIONS:

- System Aural Sweep Test 6.0V Input 50Hz to 20kHz
- L.F. Aural Sweep Test 5.0V Input 50Hz to 3kHz
- H.F. Aural Sweep Test 2.83V Input 2kHz to 20kHz

PHYSICAL SPECIFICATIONS:

- Dimensions 13-3/4" x 8-7/8" x 13" (350mm x 225mm x 330mm)
- Weight 20.7 lb (9.4kg) Each
40 lb (18.8kg) Sold in Pairs

WARRANTY:

- Refer to Warranty Statement packed with each product.

* The maximum recommended amplifier power rating will ensure proper system headroom to allow for occasional peaks. We do not recommend sustained operation at these maximum power levels.

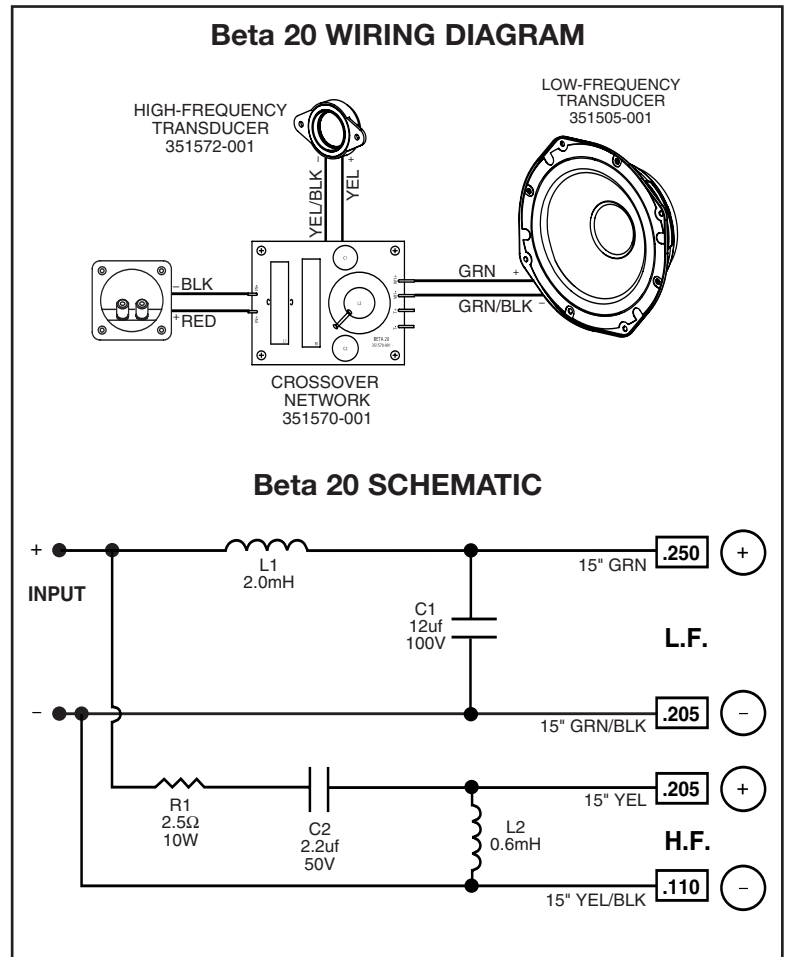
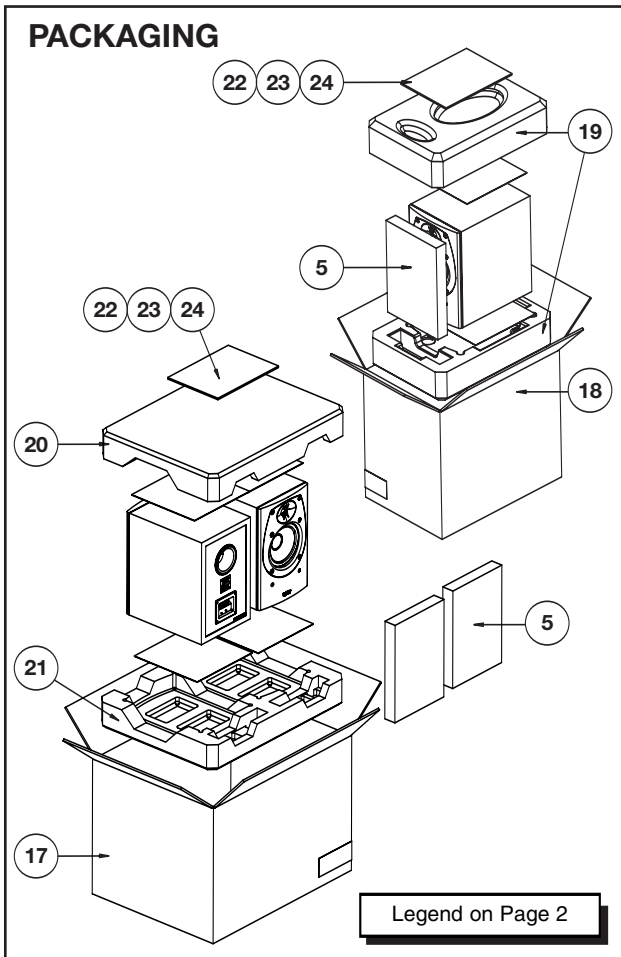

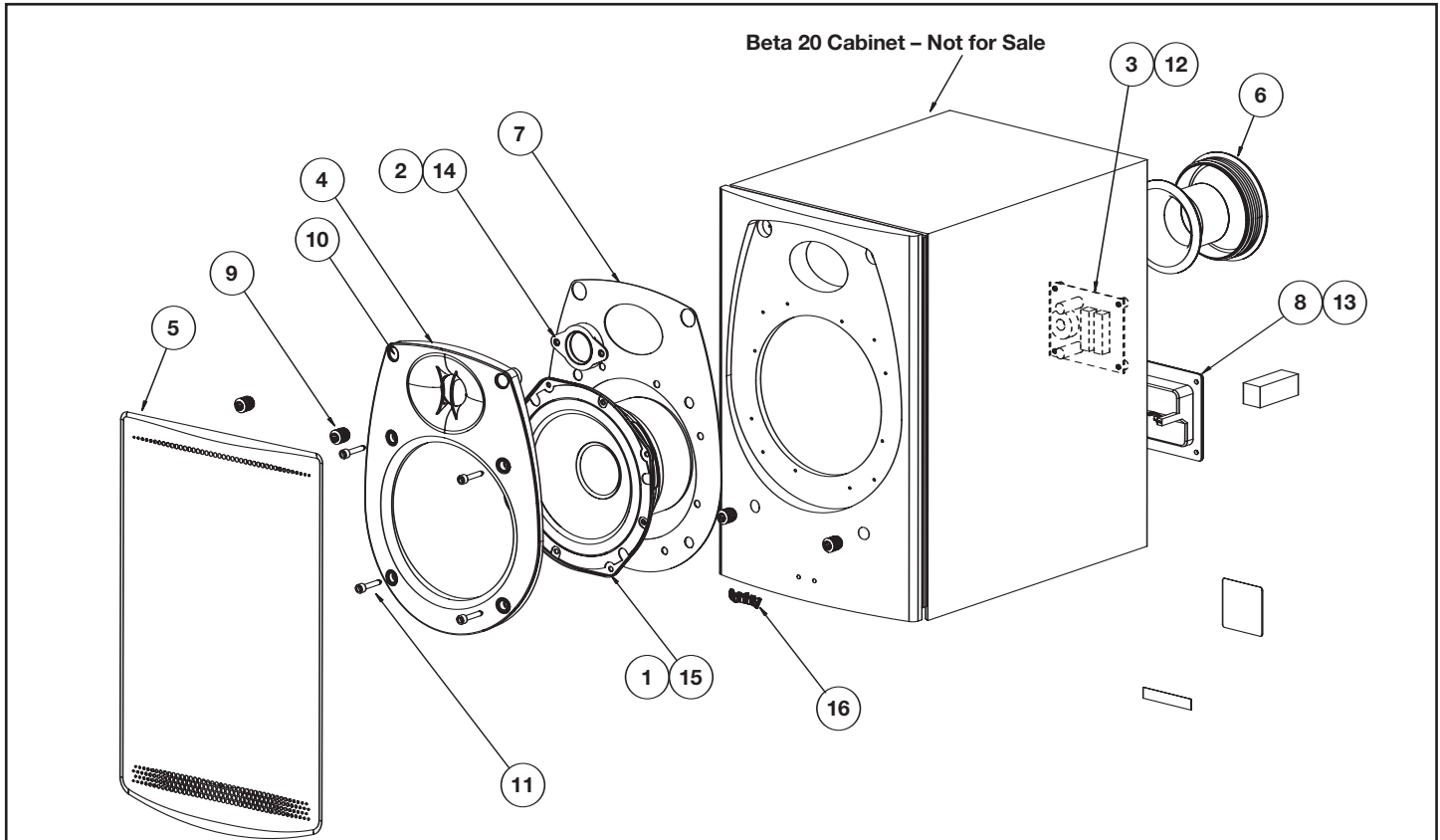

ITEM NO.	DESCRIPTION	QTY.	PART NO.	ITEM NO.	DESCRIPTION	QTY.	PART NO.
1.	Woofer, BT165HWS	1	351505-001	13.	Screw (terminal cup) #6 x .75", PH, PB, BLK	4	63563
2.	Tweeter	1	351572-001	14.	Screw (tweeter mounting) MS, PPH, H/L, 6-19 x .375"	2	905401-006
3.	Crossover Network	1	351570-001	15.	Screw (woofer screws) PB, PPH, #8 x .75" BLK	8	900101-012
4.	Faceplate, Black (for BK)	1	351569-001	16.	Logo, Gold/Silver Infinity	1	351617-001
	Faceplate, Gray (for BE & CH)	1	351569-002	17.	Carton-Beta20BK-Pair Pack	1	352070-001
5.	Assy, Grille, Black (for BK)	1	352006-003		Carton-Beta20BE-Pair Pack	1	352070-002
	Assy, Grille, Gray (for BE & CH)	1	352006-004		Carton-Beta20CH-Pair Pack	1	352070-003
6.	Assy, Port Tube	1	351768-001	18.	Carton-Beta20BK-Single Pack	1	352987-001
7.	Gasket, Faceplate	1	351921-001		Carton-Beta20BE-Single Pack	1	352987-002
8.	Terminal Cup w/Binding Posts	1	338567-001		Carton-Beta20CH-Single Pack	1	352987-003
9.	Cup, Grille (Black for BK)	4	333249-001	19.	End Pad, Top & Bottom Single Pack	2	352136-001
	Cup, Grille (Gray for BE & CH)	4	333249-003	20.	End Pad, Top Pair Pack	1	352072-001
10.	Screw (faceplate 2 top screws only) PB, FPH, #6 x .75"	2	907502-012	21.	End Pad, Bottom Pair Pack	1	352072-002
11.	Screw (faceplate bottom 4 screws) PB, HXS, #8 x 1" BLK	4	903802-016	22.	Foot, Bump-on, 3M SJ5744 (set)	1	330104-001
	BLACK ONLY #8 x 1" 10HD 5/32 DR	4	72216	23.	Owner's Manual	1	352036-001
12.	Screw (network) PB, OVHDPH, #6 x .75"	4	61867	24.	5 Year Warranty Card, Infinity	1	335841-003

TO SERVICE THE BETA 20

1. Remove the grille.
2. Remove the (2) rubber grille retainers on the mid/twt faceplate; this can be accomplished by carefully pulling them out of their cavities with long-nosed pliers or similar tool.
3. Remove the (2) Phillips screws that are now exposed.
4. Remove the (4) remaining Hex screws on the front faceplate.
5. Carefully separate the front faceplate, with tweeter attached, from the cabinet.
6. Remove (8) remaining woofer screws if necessary.